

GALVANİZ LITYUM-ION AKÜLÜ TRANSPALET

Model / Model		SMART 20 G	
Art. No / Art. Nr.		50500044-21	
Kapasite / Capacity	Q	2000	kg
Yük Merkezi / Load Center	c	600	mm
Dıştan dışa çatal genişliği Standart overall fork width	b1	550	mm
Çatal uzunluğu / Fork length	l	1150	mm
Makine uzunluğu / Overall length	l1	1552	mm
Kaldırma / Lift	h3	115	mm
Makine yüksekliği (kol sürüş pozisyonunda) Height of tiller in drive position, min./max.	h14	735/1170	mm
Makine yüksekliği (çatal indirilmiş) Height, fork lowered	h13	82 ± 2	mm
Min. dönme yarıçapı Minimum turning radius	Wa	1353	mm
Dingil mesafesi Wheelbase	Y	1197	mm
Çatal ebatları Fork dimensions (h x w x l)	s/e/l	58/160/900	mm
Koridor genişliği (1000x1200 mm palet) çapraz Aisle width for pallets 1000x1200 crossways	Ast	2376	mm
Koridor genişliği (800x1200 mm palet) uzunlamasına Aisle width for pallets 1000x1200 lengthways	Ast	2257	mm
Sürüş hızı (yükli - yüksüz) / Max Traveling speed (laden- unladen)		4.0 / 4.5	km/h
Kaldırma hızı (yükli - yüksüz) / Lifting speed (laden- unladen)		18/23	mm/s
İndirme hızı (yükli - yüksüz) / Lowering speed (laden- unladen)		56/46	mm/s
Maks. tırmanma (yükli - yüksüz) / Max Gradeability (laden- unladen)		6 / 20	%
Sürüş motoru / Travelling		DC 1.0	kw
Kaldırma motoru / Lift motor		DC 0.8	kw
Akü voltaj / Nominal capacity		48 / 15	V/ Ah
Sürüş freni / Travelling brake		Regenerate	
Gürültü seviyesi / Sound level at the driver's ear according to EN 12053		<70dB	dB(A)
Uzaktan kumanda / Remote control		+	
Tekerlek / Wheel		PU	
Tekerlek ebatları ön/ Wheel size, front		140x55	mm
Tekerlek ebatları arka/ Wheel size, rear		80x93(single wheel) 80x70(tandem)	mm
Fren / Travel brake		Elektromanyetik	
Ağırlık (akü dahil) / Weight (with battery)		128	kg



Çift yön PU teker



Elektrikli kaldırma/indirme



48V 15Ah Lityum Akü



Boyutlar

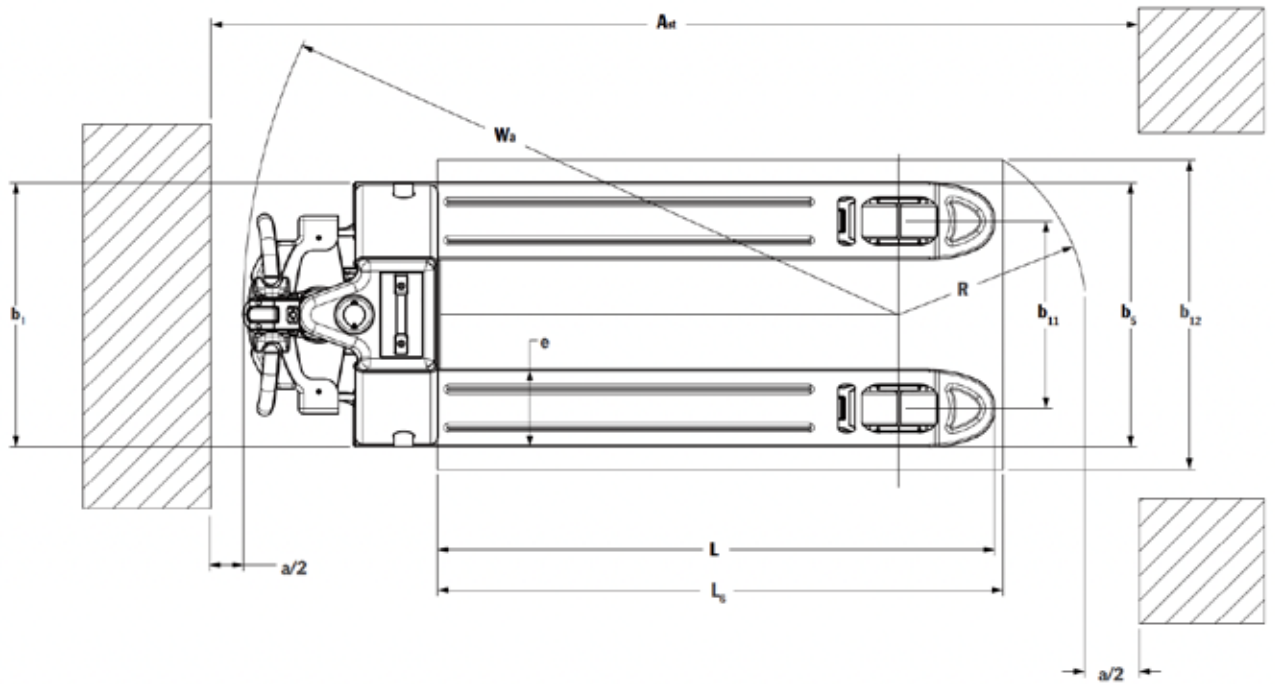
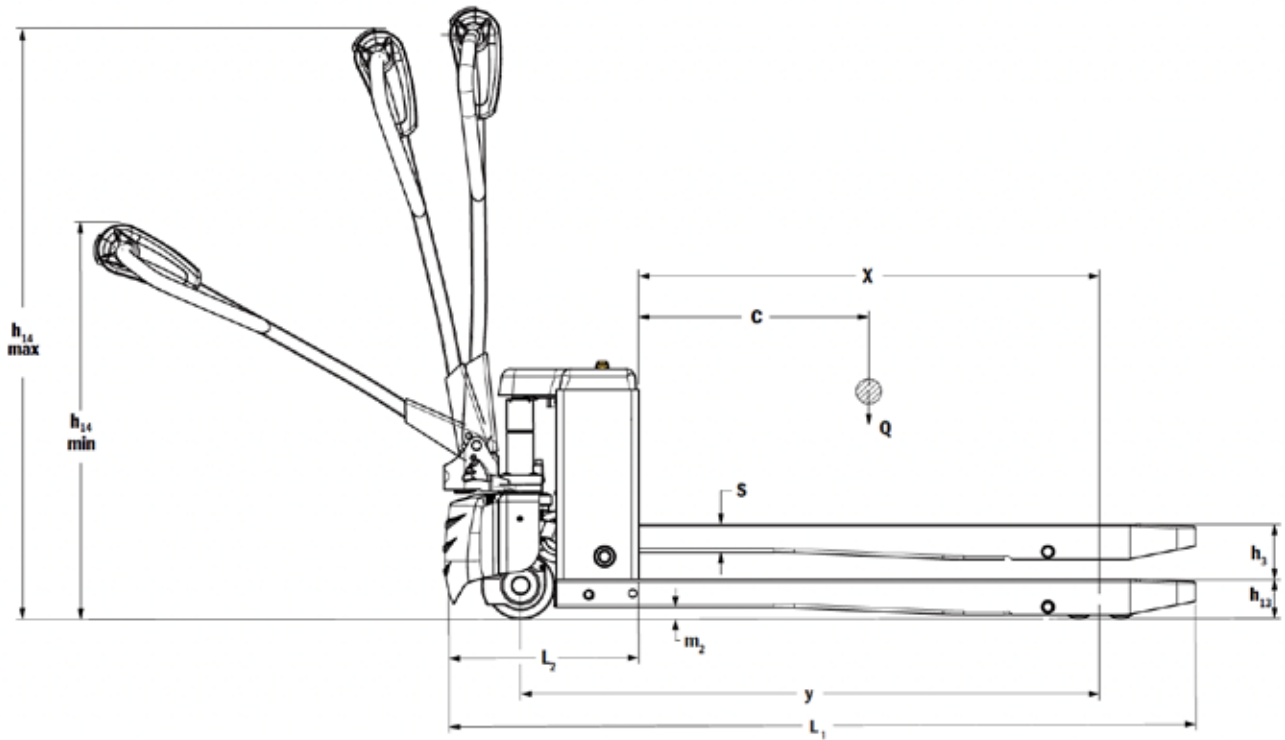

ÖZELLİKLER

Korna
Göğüs butonu
(Acil durdurma)

İleri/Geri Kelebek butonu
İndirme /Kaldırma

LCD EKРАН
Akü seviyesi
Hata kodu
Şarj uyarısı

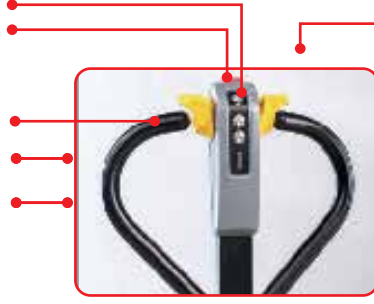

ÇOKLU FOKSİYONEL KOL
(Kaldırma ve yürütme akülü)

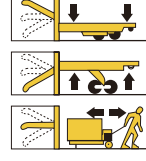

ÇOKLU FOKSİYONEL KOL
(Yürütme akülü)



ÇİFT YÖN TEKER



Li-ION AKÜ



AKÜ KORUMA



SAĞLAM GÖVDE YAPISI



HARİCİ ŞARJ CİHAZI



YÜRÜYÜŞ GRUBU KORUMA KAPAĞI



MANUEL: KALDIRMA/ İNDİRME



ELEKTRİK: KALDIRMA/ İNDİRME